

5 Phase Stepping Motor Driver MC-5528P/5528P-3



RoHS

FEATURE

- Maximum drive current 2.8A/phase.
- It is 5 Phase-stepping motor driver of the AC100-115V input.
- Maximum resolution is 1/250 (125,000 pulse per rotation).
- Low vibration drive(Full or Half step). (Except MC-5528P-3)
- I/O uses the connector.

SPECIFICATION

Name	5 phase stepping motor driver
Model	MC-5528P, MC-5528P-3
Driving method	Micro step
Input power	AC100~115V ±10% 50/60Hz 6.5A Max.
Drive current	2.8A/phase Max.
Division	MC-5528P 1, 2, 4, 5, 8, 10, 16, 20, 25, 40, 50, 80, 100, 125, 200, 250 MC-5528P-3 1, 2, 3, 6, 12, 18, 24, 32, 36, 48, 60, 72, 120, 160, 180, 240
Maximum frequency	500 kpps
Input signal	Optical-isolator input [1]:4~8V, [0]:-8~0.5V Input resistance CW, CCW:300Ω C.D, H.O, D.S:390Ω
Output signal (Z.P)	Optical-isolator open corrector output Condition : DC30V or less, 50mA or less
Function	Pulse input mode selector, Automatic current reduction, Micro step angle select, Driving voltage select, Initial system check
Insulation resistance	The value is 50MΩ or more, that measured by DC500V Megger Between the AC input and the case.
Withstand voltage	It is not above even if AC1500V is impressed between the AC input and the case for one minute.
Operating temperature range	0~40°C
Operating humidity range	0~85%
Weight	1.1kg

SAMPLE WIRING DIAGRAM

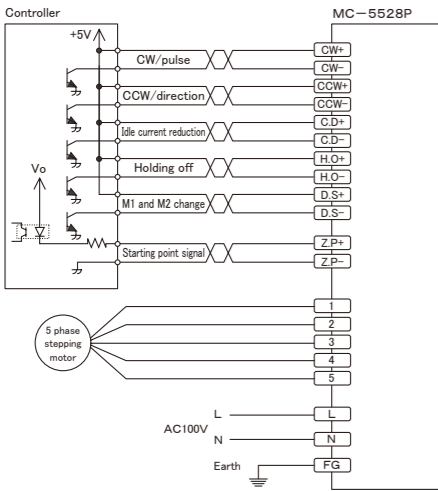

DIMENSIONS (unit:mm)

The size does not contain the projection thing such as the screws.

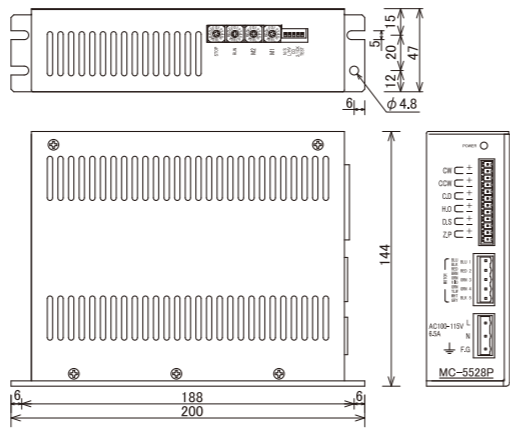

MOTOR

- 5/10 lead 5-Phase stepping motors such as Tamagawa-seiki or Oriental-motor.

See table below for the pin no. of the connector and color of motor leads.

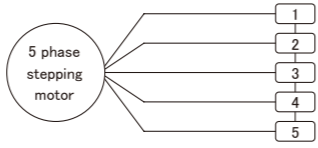

Connector No.	5 lead	10 lead
1	Blue	Blue/Black
2	Red	Red/Blown
3	Orange	Orange/Purple
4	Green	Green/Yellow
5	Black	White/Gray

Note : Please use the wire rod of AWG18(0.75mmsq) or more for connecting the motor.

INPUT/OUTPUT CIRCUIT

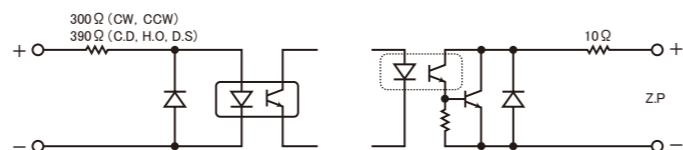

NAME AND FUNCTION

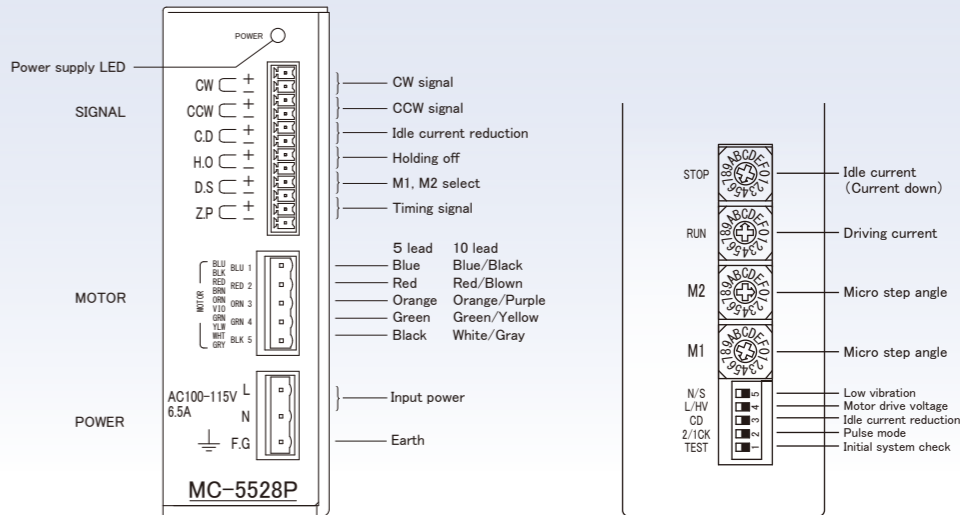

SETTING MICROSTEP RESOLUTION

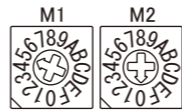

MC-5528P	SW No.	0	1	2	3	4	5	6	7	8	9
Division		1	2	4	5	8	10	20	40	80	16
	A	B	C	D	E	F					
	25	50	100	125	200	250					

MC-5528P-3	SW No.	0	1	2	3	4	5	6	7	8	9
Division		1*	2*	3	6	12	18	24	32	36	48
	A	B	C	D	E	F					
	60	72	120	160	180	240					

$$\text{Micro Step Angle} = \frac{\text{Base Step Angle}}{\text{Division}}$$

72 divided steps → 0.01 degree
*Does not drive at the low vibration in this case.

- ① When only one microstep angle is used, use M1 rotary switch to set the division. input terminal D.S shall not be connected or signal must be ZERO(0) state if it is connected.
- ② Input signal at D.S Terminal. Zero(0) = M1 division, One(1) = M2 division. Speed of Forward & Backward speed can be changed by this function.

SETTING DRIVE CURRENT

The desired drive current is obtained by setting RUN SW as follows.



MC-5528P	SW No.	0	1	2	3	4	5	6	7	8	9
Current (A)		1.0	1.15	1.3	1.45	1.6	1.75	1.9	2.05	2.2	2.35
	A	B	C	D	E	F					
	2.5	2.65	2.8	2.95	3.1	3.25					

Example ; Drive current = 2.8A/phase.
RUN SW = C

SETTING IDLE CURRENT (CURRENT DOWN)

Idle current is established by setting STOP SW as follows.



MC-5528P	SW No.	0	1	2	3	4	5	6	7	8	9
Current (%)		25	30	35	40	45	50	55	60	65	70
	A	B	C	D	E	F					
	75	80	85	90	95	100					

Example ; When the drive current is set at 1.4A/Phase, idol current will be 0.7A/Phase at the switch position no. 5 (50%).

DIP SW FUNCTIONS



No.	Indication	Mode	ON	OFF
1	TEST	Initial system check	Rotating (60pps).	Always set to off
2	2/1CK	Pulse mode	One pulse	Two pulse
3	C.D	Idle current reduction	Not active	Activated
4	L/HV	Motor drive voltage	*High speed and high torque	Standard
5	N/S	Low vibration	Low vibratino drive	Standard drive

*Please note heat of the motor when driving by high speed and a high torque.