

4 axis One Board 5 phase Microstep Driver MC-S0514-4L

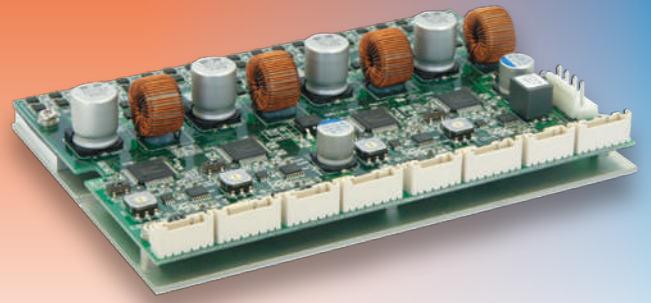

FEATURE

- More low-priced micro step driver for 4 axes.
- Drive Current : 0.35A/phase, 0.75A/phase, 1.4A/phase.
- Low vibration drive(Full or Half step).
- Optical-isolator input.
- Automatic current reduction.
- Small size.

※Optional Parts ; Wire assembled conector ▶Page 54

SPECIFICATION

Name	5 phase stepping motor driver
Model	MC-S0514-4L
Driving method	Micro step
Input power	DC24V ±5% 10A Max.
Drive current	0.35A/phase , 0.75A/phase , 1.4A/phase Switching
Division	2 series : 1, 2, 4, 5, 8, 10, 16, 20, 25, 40, 50, 80, 100, 125, 200, 250 3 series : 1, 2, 3, 6, 12, 18, 24, 32, 36, 48, 60, 72, 120, 160, 180, 240
Maximum frequency	500 kpps
Input signal	Optical-isolator input [1]:3~5V, [0]:-3~0.5V Input resistance CW, CCW:220Ω H.O:220Ω
Function	Pulse input mode selector , Micro step angle select , Automatic current reduction
Operating temperature range	0~40°C
Operating humidity range	0~85%
Weight	275g

DIMENSIONS (unit:mm)

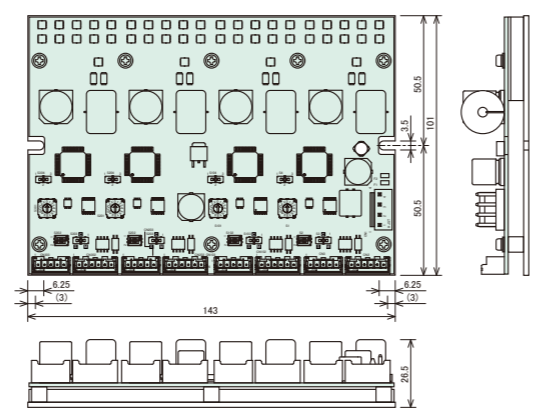

SAMPLE WIRING DIAGRAM

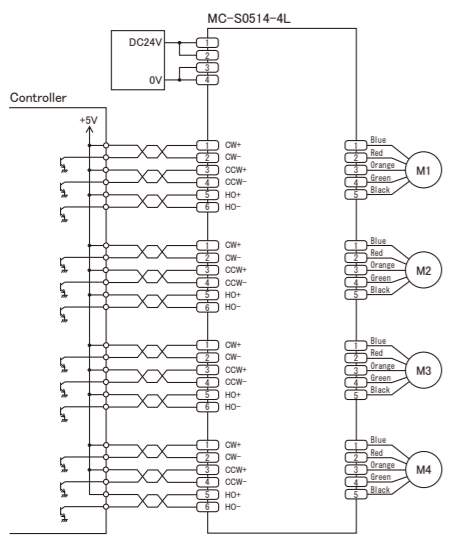

MOTOR

- 5/10 lead 5-Phase stepping motors such as Tamagawa-seiki or Oriental-motor.

See table below for the pin no. of the connector and color of motor leads.

Connector No.	5 lead	10 lead
1	Blue	Blue/Black
2	Red	Red/Blown
3	Orange	Orange/Purple
4	Green	Green/Yellow
5	Black	White/Gray

INPUT CIRCUIT

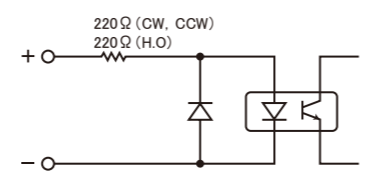

NAME AND FUNCTION

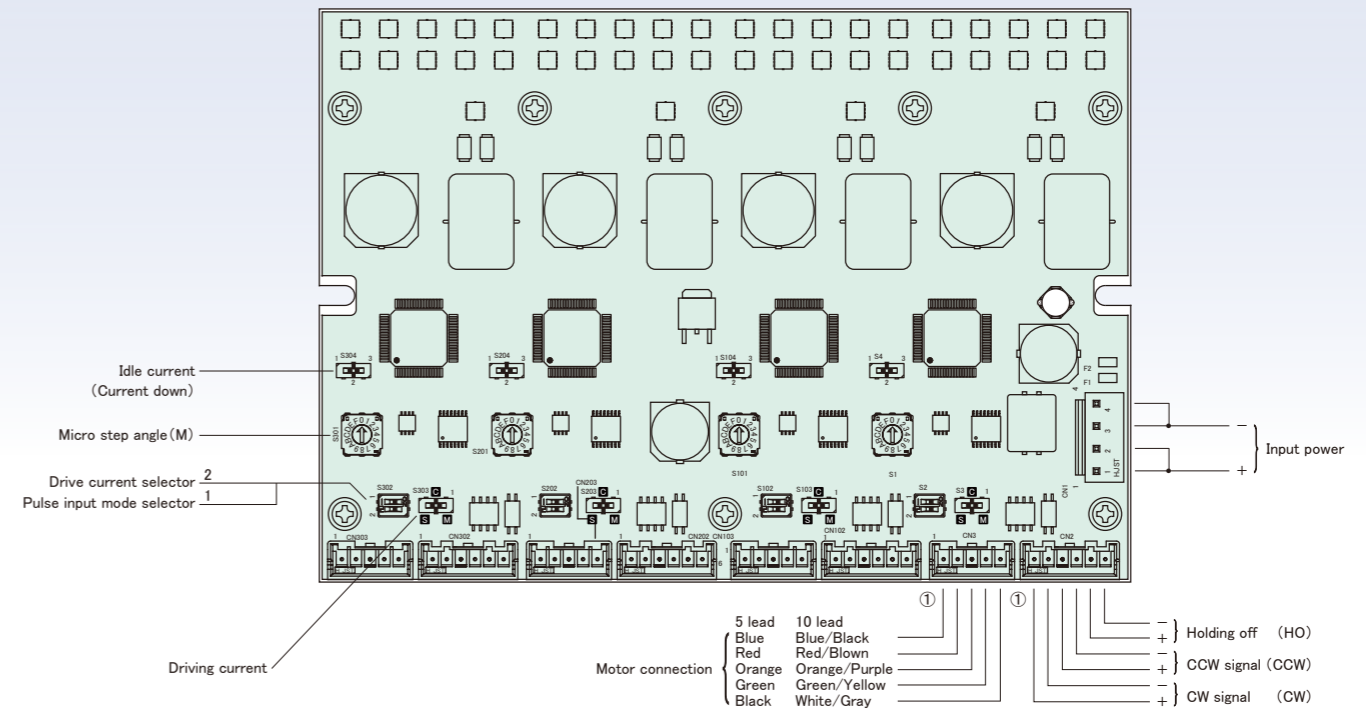

SETTING MICROSTEP RESOLUTION

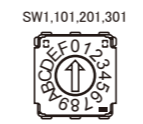

$$\text{Micro Step Angle} = \frac{\text{Base Step Angle}}{\text{Division}}$$

Resolution for 2 series : When DIP Switch SW2 is OFF.

SW No.	0	1	2	3	4	5	6	7	8	9
Division	1	2	4	5	8	10	20	40	80	16
	A	B	C	D	E	F				
	25	50	100	125	200	250				

Resolution for 3 series : When DIP Switch SW2 is ON.

SW No.	0	1	2	3	4	5	6	7	8	9
Division	1	2	3	6	12	18	24	32	36	48
	A	B	C	D	E	F				
	60	72	120	160	180	240				

SETTING DRIVE CURRENT

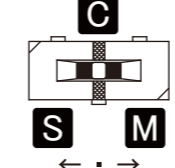

DIP Switch "S3"
for 0.75A/phase : Switch to "S".
for 0.35A/phase : Switch to "C"(Center).
for 1.4A/phase : Switch to "M".

DIP SW FUNCTION



No.	Mode	ON	OFF
1	Pulse mode	One pulse	Two pulse
2	Drive current selector	3 series	2 series

SETTING IDLE CURRENT (CURRENT DOWN)

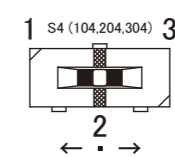

50% (Position 1)
75% (Position 2, Center)
25% (Position 3)
※Figures are of ratios to the drive current.